



Make sure your connection is secure!

Fifth wheel couplings and king pins are both subject to a certain amount of wear, depending on their operating conditions. This can be discovered when backlash towards the direction of motion is noticeable. Too much backlash can lead to surging and can cause a threat to safety on the roads and damage to the fifth wheel coupling, the mounting plates, and the chassis.

The locking mechanism of JOST fifth wheel couplings is factory-adjusted so that in conjunction with a new king pin there is horizontal play of approx. 0.3 mm in the direction of travel. The horizontal play can reach up to 2 mm through wear and tear on the lockjaw or the wearing ring. All JOST fifth wheel couplings allow for continuous adjustment to compensate for wear in the coupling locking mechanism. Only when the scope for adjustment has been exhausted is it necessary to replace the wearing parts.

Wear on king pins should not be compensated by readjusting the fifth wheel coupling. Once the king pin has reached its wear limit, it must be replaced. Once the king pin has been replaced, the locking mechanism on the fifth wheel coupling must also be readjusted.

Depending on operating conditions, the mounting plate, the king pin and the fastening elements should be examined for wear and tear, damages, cracks and functional failures at least every six months or after 50,000 km, and repaired if necessary. JOST wear limit gauges and the fifth wheel test unit are important aids for this.

Wear limits

2"

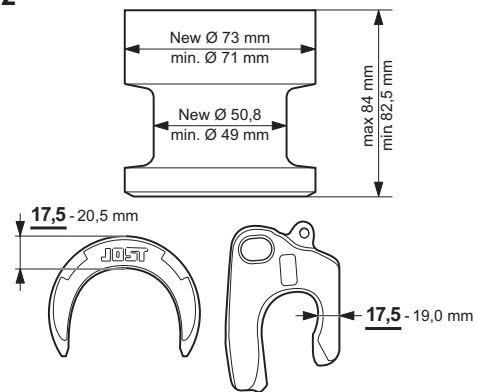

3,5"

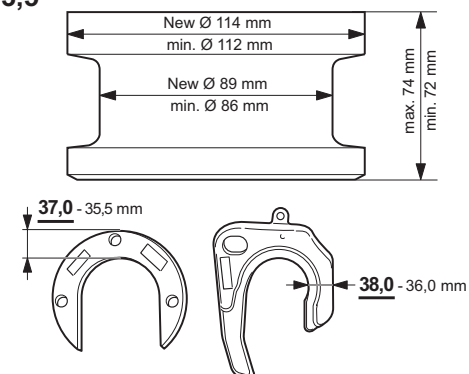

The advantages of regular inspection and adjustment for you

- Increased road safety by avoiding impermissible horizontal play
- Longer life span of fifth wheel coupling, mounting plate and vehicle frame. More comfortable driving experience



Wear limit gauges

Application

With the JOST wear limit gauge it is possible to determine, in a decoupled and closed state, whether the locking mechanism of the fifth wheel coupling or the king pin has reached or exceeded the maximum wear limit.

Your advantage

- A wear gauge for everything – for the fifth wheel coupling locking mechanism as well as for the king pin
- Simplifies the wear and tear examination and saves time
- Light and easy to handle



Item: J 1027 for 2“

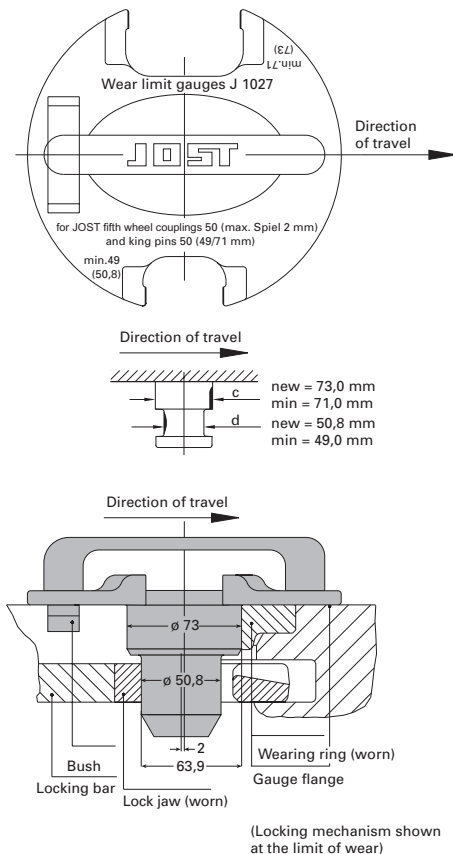

Item: J 1044 for 3.5“

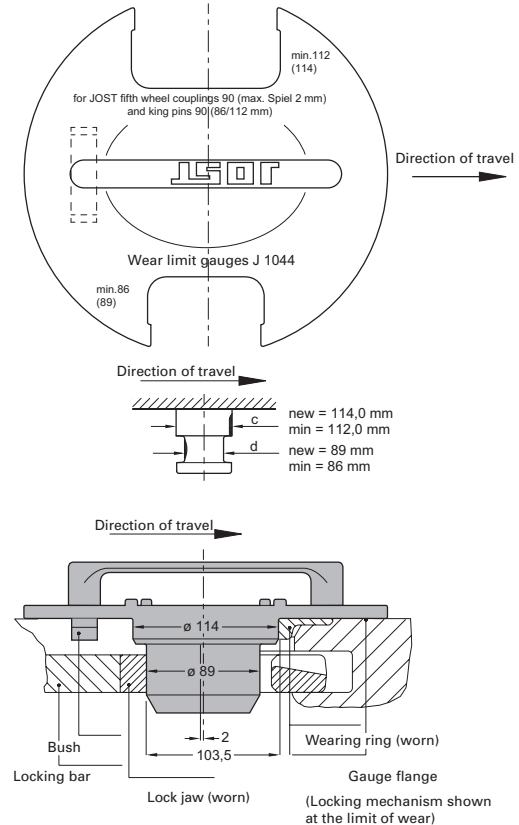



Fifth wheel test unit

Application

The JOST fifth wheel test unit is an important aid for you: The locking mechanism of JOST fifth wheel couplings can be examined and, if necessary, readjusted quickly, easily and accurately. The fifth wheel test unit is suitable for all 2" fifth wheel couplings as well as for 3.5" fifth wheel couplings when using a king pin adapter*.

Your advantage

- Adjustment is straightforward and time-saving with no need to dismantle the fifth wheel coupling or trailer
- Compact and robust
- Simplifies the adjustment of king pin sensors on sensor fifth wheel couplings



* Note:

The king pin adapter has no ECE approval and is not suitable for use on public roads

Item: **SKE 008630000**

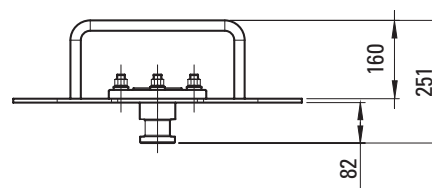
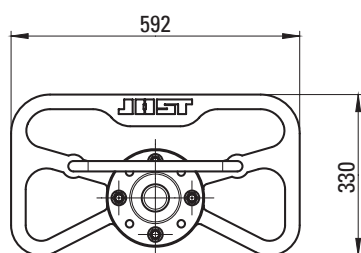

Wear Limit Gauge and Fifth Wheel Test Unit

For a secure connection

