

JOST

Montage- und Betriebsanleitung

KUGELLENKRÄNZE

BAUREIHEN HE, HE-W, SO, KDL-W, L, N UND ND



- Ⓒ **Installation and operating instructions**
- Ⓕ **Instructions de montage et de d'utilisation**
- Ⓘ **Istruzioni per il montaggio e l'uso**
- Ⓔ **Instrucciones de montaje y funcionamiento**



Technical modifications reserved. The latest information can be found at: www.jost-world.com.

1 Safety instructions	16
1.1 Safety information for servicing	16
1.2 Safety information for installation	16
2 Correct use	16
2.1 Design	16
3 Assembly	17
3.1 Standard fitting	17
3.2 Fitting instructions	18
3.3 Special fitting	18
3.4 Welded stops	19
3.5 Painting	19
3.6 Fitting material and tightening torque values	20
4 Commissioning	21
4.1 Standard turntables or slewing rings	21
4.2 Low maintenance turntables or slewing rings	21
4.3 JOST Central lubrication manifold (8x)	21
5 Servicing	22
5.1 Standard turntables or slewing rings	22
5.2 Low maintenance turntables or slewing rings	22
6 Wear test	23

1 Safety information

1.1 Safety information for servicing

- ▶ Only use the specified lubricants for the servicing work.
- ▶ The servicing work should only be completed by trained personnel.

1.2 Safety information for installation

- ▶ Do not change the installation area defined by the manufacturer of the trailer.
- ▶ The installation work may only be completed by authorised personnel.
- ▶ Refer to the instructions issued by the trailer manufacturer, for example the type of fitting and mounting constructions.
- ▶ Follow the installation instructions supplied by the trailer manufacturer.

In Germany you must comply with the TÜV regulations and the Road Traffic and Registration Directive (StVZO).

2 Proper usage

2.1 Design

Turntables (KLK) and slewing rings (KDL) are parts for mounting on trailers and agricultural vehicles, to form a rotary connection between the A-frame and the trailer chassis. They must be operated at all times in compliance with the operating manual for the relevant vehicle.

The maximum load data for JOST turntables and slewing rings are set out in the details in the JOST product catalogue.

Turntables and slewing rings are designed exclusively for turning motions.

Please ask us if you intend to use them for other applications.

3.1 Standard fitting

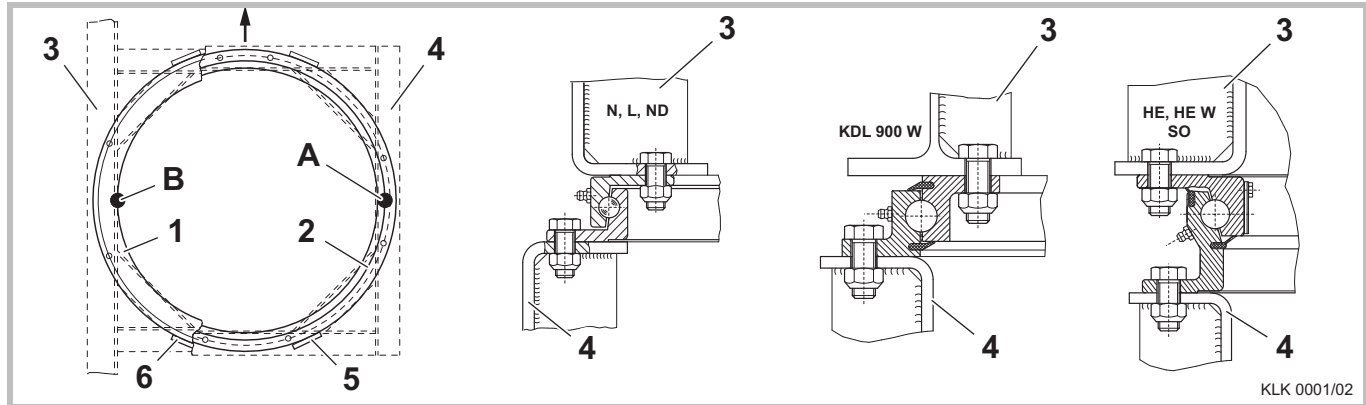

- 1 Upper ring
- 2 Lower ring
- 3 Chassis
- 4 A-frame
- 5 Lower welded stops
- 6 Upper welded stops

- A** Position of the **type plate** (for all model series)
- B** Position of **ball insertion hole** (on series HEW, SO, KDLW and on turntables HE4 and HE5)

Note

On series HE, L, N and ND the ball insertion hole is below the type plate in position **A**.

The turntable or slewing ring must be installed on a flat (max. warpage 1 mm) mounting construction that is resistant to torsion and longitudinal and lateral movement.

At least 50% of the flange areas must be supported to ensure an adequate force transfer. The support zones must be evenly distributed longitudinally and laterally and be designed so that the turntable or slewing ring is supported around its vertical profile bars, in other words the ball race. Large flatness deviations may be compensated by metal strips.

3 Installation

In addition if the turntable or slewing ring has no holes, you must bear the following in mind when drilling the mounting holes.

- ▶ That no drill chips or cutting fluid gets into the raceway.
- ▶ That no holes are drilled in the vicinity (± 15 mm) of the ball insertion hole or in the vicinity of the welds.
- ▶ That the type plate is placed at 90° to the right of the vehicle and, if the ball insertion hole is inside, this is placed at 90° to the left of the vehicle to remove the smaller cross-sections from the area under maximum stress.
- ▶ That the grease nipples are easily accessible.
- ▶ That the components rotate freely.

3.2 Fitting instructions

Use bolts of strength class 8.8 to fasten the turntable (see section 3.6). The bolt connections are to be secured using state of the art methods to prevent them coming loose.

The turntable or slewing ring must not be fastened by welding.



The general rule is that the coating thickness of the paintwork around the securing area of the bolts must be no more than 170 μm per component to ensure a perfect friction connection.

3.3 Special fitting

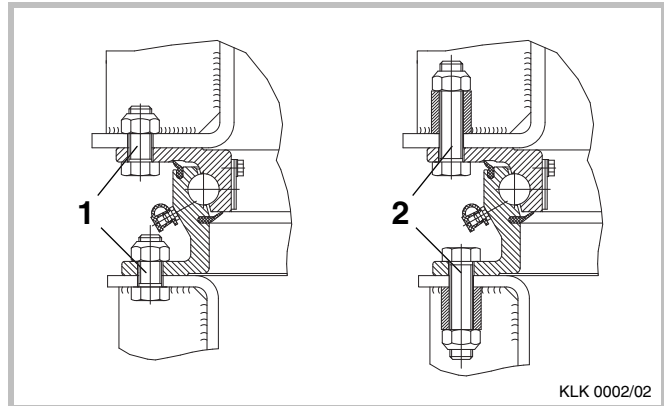

Note

If it is to be used in difficult conditions we recommend that the bolts be installed with spacer sleeves or that more bolts be used to maintain the correct prestressing force. The latter particularly applies to diameters of over 1200 mm. For different bolt connections, as shown in positions (1) and (2), it is essential to ensure that the turntable can move easily, particularly near the grease nipples and type plate.

Special fitting with JOST splined bolts (fitting without welded stops)

When used on single-axle A-frame steering systems at axle loads of up to 10 t, the standard hole patterns can be used as per the JOST product data sheet in combination with splined bolts for attachment to the vehicle without the use of welded stops.

If the axle load of the A-frame is greater than 10 t, we recommend using **at least 12** securing points per ring, distributed as evenly as possible, with splined bolts.

3 Installation

In order to ensure that the installation of the turntable or slewing ring is as tension-free as possible, a hole pattern positioning accuracy on the vehicle side of 0.6 mm and a hole diameter of 18 +/- -0.1 mm must be complied with.

More detailed information can be found in our installation instructions for JOST splined bolts.

3.4 Welded stops

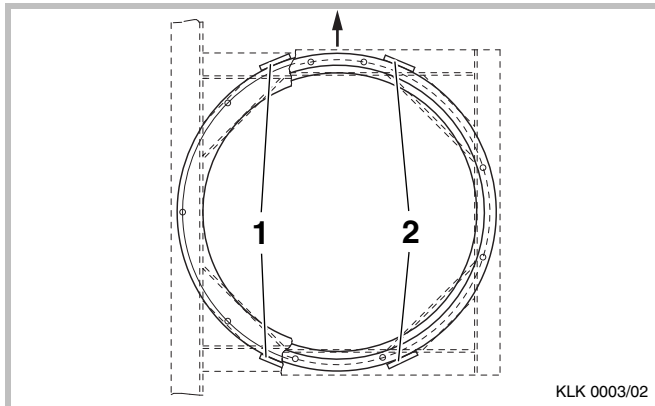

To relieve the bolts of thrust forces acting horizontally, the installed turntable or slewing ring must be holed on each flange with four welded stops with zero play. Use the welding methods set out by the trailer manufacturer for this purpose.

In cases of special fitting with JOST splined bolts (Section 3.3), the requirements on the welded stops do not need to be met.

3.5 Painting

JOST series HE, HEW, SO, ND and KDL are equipped with permanent cathodic dip coating (CDC). The CDC offers the ideal surface sealing method and therefore excellent protection against corrosion. Thanks to the evenly thin coating, overpainting is possible at all times.

Series L and N are equipped with primer that allows painting along with the trailer.

For versions with rubber washers you must ensure that the drying process takes place in controlled conditions in a heat chamber (max. air temperature 75 °C). If the washers have been glued by the paint, release them at the edge with a blunt instrument. Avoid additional paint application on the bolting areas as a result of the adverse settlement properties of the bolt connections.

3.6 Fitting material and tightening torque values

Series	Bolts of quality class 8.8	Torque ¹⁾
HE/HE W	Min. 8 hexagon bolts per ring section DIN EN ISO 8765/8676 (DIN 960/961) M16 x 1.5 Alternatively DIN EN 24014 (DIN 931) M16	225 Nm 210 Nm
SO	Min. 8 hexagon bolts per ring section DIN EN ISO 8765/8676 (DIN 960/961) M16 x 1.5 Alternatively DIN EN 24014 (DIN 931) M16	225 Nm 210 Nm
KDL 900W Diameter <= 750 mm	Min. 8 hexagon bolts per ring section DIN EN ISO 8765/8676 (DIN 960/961) M16 x 1.5 Alternatively DIN EN 24014 (DIN 931) M16	225 Nm 210 Nm
KDL 900W Diameter > 750 mm	Min. 12 hexagon bolts per ring section DIN EN ISO 8765/8676 (DIN 960/961) M16 x 1.5 Alternatively DIN EN 24014 (DIN 931) M16	225 Nm 210 Nm
L/N Diameter <= 650 mm	4 to 6 hexagon bolts per ring section DIN EN ISO 8765/8676 (DIN 960/961) M10 x 1.25 or: M12 x 1.5 Alternatively DIN EN 24014 (DIN 931) M10 or M12	52 Nm 89 Nm 49 Nm 85 Nm

Series	Bolts of quality class 8.8	Torque ¹⁾
L/N Diameter > 650 mm	Min. 8 hexagon bolts per ring section DIN EN ISO 8765/8676 (DIN 960/961) M10 x 1.25 or M12 x 1.5 Alternatively DIN EN 24014 (DIN 931) M10 or M12	52 Nm 89 Nm 49 Nm 85 Nm
ND	Min. 8 hexagon bolts per ring section DIN EN ISO 8765/8676 (DIN 960/961) M14 x 1.5 Alternatively DIN EN 24014 (DIN 931) M14	145 Nm 135 Nm

¹⁾ Setting value, tighten the bolts connection with torque wrench
DIN EN ISO 6789, class A or B.

Series	Nuts of quality class 8
All	DIN EN ISO 7042 (DIN 980)

Note

The values shown above are guide values for a coefficient of friction μ tot. = 0.14. For further information refer to VDI 2230. Tighten the bolts crossways using a suitable tool. If you fasten the turntable with fewer bolts or with smaller bolts, you must at least achieve the same overall strength.

Standard fitting for turntables of diameter 1000, 1100, 1200 and 1300

Fitting set KLE0000500 (16 screws M16 x 1.5 x 55 - 8.8, 16 nuts M16 x 1.5 - 10 and 8 welded stops)

Special fitting with JOST splined bolt

Min. 8 JOST splined bolts M16x55-10.9 per ring section and matching JOST nuts M16-10.9, tightening torque 300 Nm.

Fitting set KLE0000300 (16 splined bolts and nuts)

Fitting set KLE0000400 (24 splined bolts and nuts)

4.1 Standard turntables and slewing rings

Standard turntables or slewing rings are supplied with a thin coating of lubricant.



Before being used for the first time the turntable must be greased thoroughly by inserting a high quality grease (lithium saponified NLGI consistency class 2) through all the grease nipples and a closed grease bead should be used to seal the gaps against the ingress of dirt and spray water. We recommend JOST high performance lubricant (Art. No. SKE 005 670 000).

4.2 Low maintenance turntables and slewing rings

Low maintenance turntables or slewing rings (green type plate) are supplied with a full charge or special grease, which, in combination with the two washers, means that they require absolutely no maintenance for up to three years or 300,000 km in normal conditions. No greasing is required when the components are used for the first time.

After surpassing the above maintenance-free time/distance the turntable or slewing ring must be greased thoroughly.

Note

If you use a central lubrication manifold you should use a high quality roller bearing grease (lithium saponified, NLGI consistency min. 1). Ensure that you connect at least 6 grease nipples. We recommend using JOST high performance lubricant (Art. No. SKE 005 670 000).

4.3 JOST Central lubrication manifold (8x)

To make re-lubrication easier, we recommend the JOST JOST Central lubrication manifold.

This can be obtained as retrofit kit KLE0000200 or pre-installed.

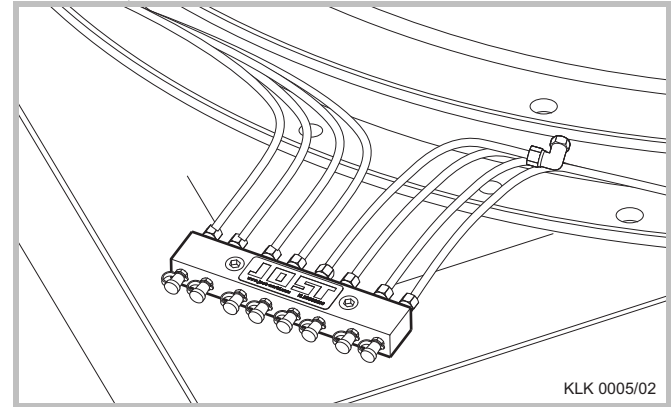

5.1 Standard turntables and slewing rings

The turntable or slewing ring must be greased with a high quality grease (lithium saponified, NLGI consistency class 2) at least every 8,000 to 10,000 km or once per month. This is done by moving the A-frame to and fro until a bead of grease, which is as closed as possible, is emitted over the entire circumference of the gaps or washers. We recommend using JOST high performance lubricant (Art. No. SKE 005 670 000).

- ▶ If you use the turntable or slewing ring in forced steering systems, comply with the servicing instructions supplied by the vehicle manufacturer.
- ▶ The bolt connections are to be checked as part of the vehicle inspection routine but at the latest after 50,000 km, to ensure they still comply with the specified tightening torques.
- ▶ Check for signs of wear (see section 6).
- ▶ Check the turntable or slewing ring and its fitting elements for signs of excessive corrosion, damage and cracks.

5.2 Low maintenance turntables and slewing rings

Low maintenance turntables or slewing rings require no maintenance for up to 3 years or 300,000 km in normal conditions. The prerequisite for this, however, is that no mechanical damage has been suffered by the washers and that the vehicle is not cleaned near the bearing seals with high pressure or steam jets. The components must be greased before the end of the maintenance-free period if the turntable is used in difficult conditions or cleaned using intensive methods. After the elapse of the maintenance-free period the low maintenance turntable or slewing ring should undergo the same treatment as standard versions.

- ▶ If you use the turntable or slewing ring in forced steering systems, comply with the servicing instructions supplied by the vehicle manufacturer.
- ▶ The bolt connections are to be checked as part of the vehicle inspection routine but at the latest after 50,000 km, to ensure they still comply with the specified tightening torques.
- ▶ All other greasing intervals are 8,000 to 10,000 km or once per month.
- ▶ Check for signs of wear (see section 6).
- ▶ Check the turntable or slewing ring and its fitting elements for signs of excessive corrosion, damage and cracks.
- ▶ In cases of off-road use, we strongly recommend also carrying out interim lubrications within the 3-year servicing-free period.

6 Wear test

Turntables and slewing rings are wear parts. Regular and effective lubrication is essential to obtain a long service life from them. When the gap size reaches its minimum value the wear limit has been reached. This occurs at the latest when at any point on its circumference the horizontal gap X has reached the value shown in the table below.

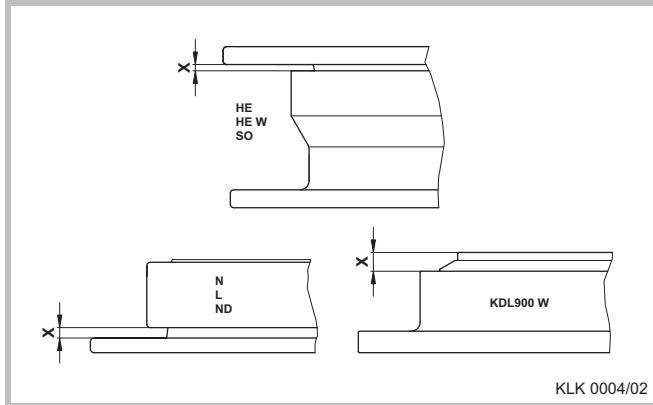

Series	Maximum axial play	Minimum air gap X
HE/SO	3.5 mm	0.0 mm
HE W	3.5 mm	2.2 mm
KDL 900 W	3.5 mm	7.5 mm
L/N	2.5 mm	0.0 mm
ND	3.5 mm	0.0 mm



Siemensstraße 2, D-63263 Neu-Isenburg, Telefon +49 6102 295-0, Fax +49 6102 295-298, www.jost-world.com

ZDE 199 001 010 05/2013