

# RO★244-2



Reparaturanleitung | Repair instructions | Manuel de réparation

## ROE47137

- ① Kupplungsbolzen
- ② Coupling pin
- ③ Axe d'accouplement

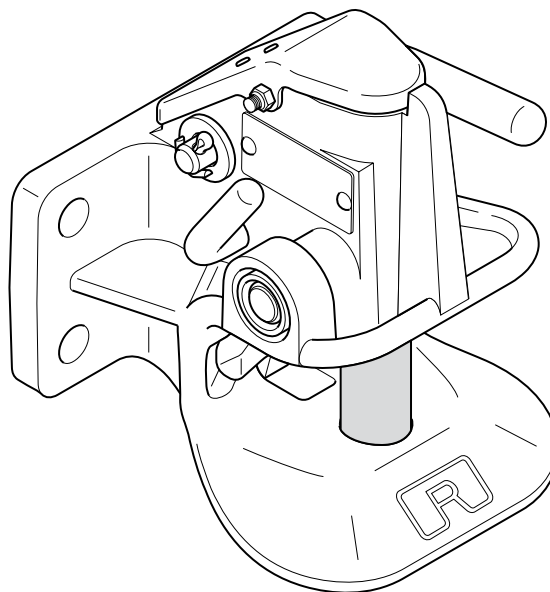

**(D) Voraussetzung zum Wechsel des Kupplungsbolzens sind die Schritte 1.1 - 1.3!**

Allgemeines	3
1.1 Handhebel	5
1.2 Sperrhebel	7
1.3 Schließhebel	9
1.4 Kupplungsbolzen	11
2.1 Funktionsprüfung	13

**(GB) The steps 1.1 - 1.3 are a precondition for the change of the coupling pin!**

General	15
1.1 Hand lever	17
1.2 Locking lever	19
1.3 Closing lever	21
1.4 Coupling pin	23
2.1 Function check	25

**(F) Pour changer l'axe d'attelage il faut impérativement exécuter les pas 1.1 à 1.3 !**

Généralités	27
1.1 Levier à main	29
1.2 Levier d'arrêt	31
1.3 Levier de fermeture	33
1.4 Axe d'accouplement	35
2.1 Essai de fonctionnement	37

## Liability

ROCKINGER assumes no guarantee for the completeness and correctness of the information. The contents of the instructions cannot be used to substantiate any claims. In particular, no liability is assumed for damages which are the result of incorrect repair or maintenance work.

## Copyright

All the rights to these instructions and their annexes remain with ROCKINGER.

## Emphasis in the text

### Explanation of symbols

For ease of readability and to provide a clear overview, different types of information are marked in different ways.

Sentences introduced with an arrow contain instructions to perform certain actions:

- Carry out instructions one after the other in the sequence described.

The following information is introduced by a dash:

- Lists
- Preconditions for actions to be executed subsequently
- Descriptions of previous work steps
- Descriptions of statuses

### Warnings of hazards and risks

Important passages which must be observed, are especially emphasised:



#### DANGER!

Warns against immediate dangers which could lead to serious injury or death.

- Provides instructions for defence against or avoidance of dangers.

**WARNING!**

Warns against risks which could lead to serious injury or death.

- Demands safety measures to protect the persons concerned.

**CAUTION!**

Warns against risks which could lead to damage to property or personal injury (light injury).

- Provides information for prevention of damage.

**Illustrations**

As necessary, texts are illustrated by pictures. The reference to a figure is made with a number in [square brackets]. Capital letters after a figure number, e.g. [12A] refer to the corresponding position in the picture.

**Binding information****LUBRICANTS:**

- Lubricant for the previously described activity

**TIGHTENING TORQUES:**

- Tightening torques for the listed bolted connections.

**Supplementary information**

The information symbol refers to instructions and recommendations as well as additional information.

**TOOLS:**

- List of the tools necessary for the subsequently described activities.

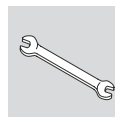

# 1.1 Hand lever

## Hand lever

### Requirements

- Coupling closed

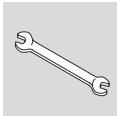

### TOOLS:

- mechanical pliers, angled
- combination pliers or pipe wrench
- flat-tip screwdriver, medium

### Removal

- Remove washer and split pin [1A]
- Remove washer and split pin [1B]



### CAUTION

- **RISK OF INJURY!** The tension on the locking spring [1A] is released when the hand lever [1D] is pulled out. Wear gloves!
- Release the tension on the locking spring [1C] by levering it out with a flat-tip screwdriver
- Pull out hand lever [1D]

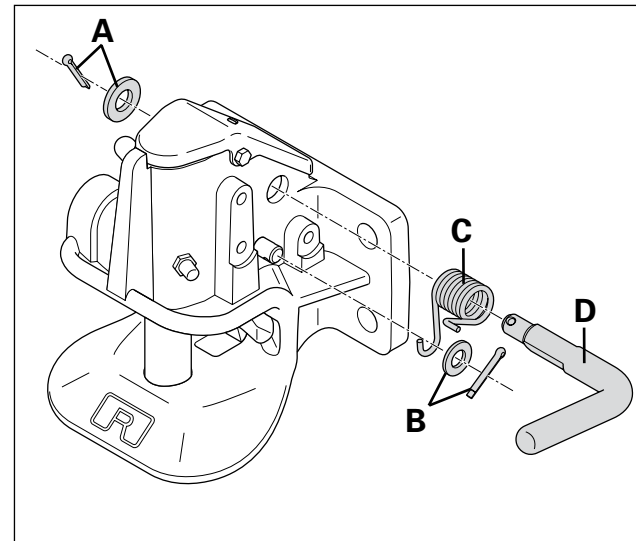

- [1] **A** Split pin and washer, hand lever  
**B** Split pin and washer, closing lever  
**C** Locking spring  
**D** Hand lever

### Installation

- Press the closing lever [2A] all the way down and hold it there
- Slide in the hand lever with spring
- Check that the hand lever is fitted correctly
- When the coupling is closed, the lever is pointing to the front
- Tension the spring with the pipe wrench and hang it onto the closing lever
- Fit washers and two new split pins [2B]
- Secure the split pins against falling out: bend the end of the pin
- Check the coupling for correct functioning; Section 2.1

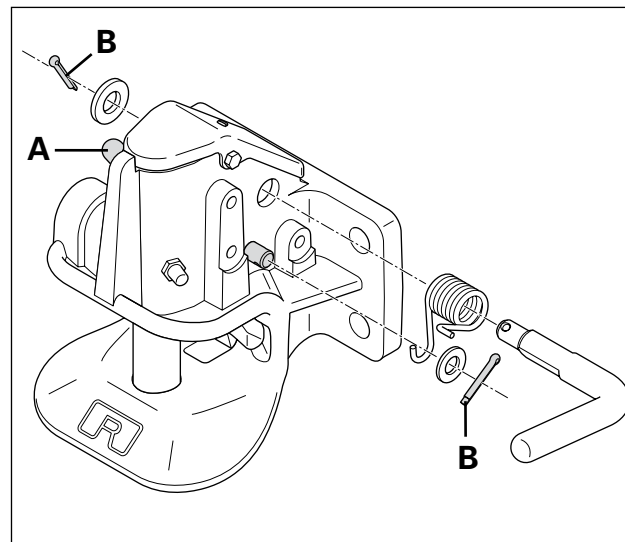

- [2] **A** Closing lever  
**B** Split pins



### LUBRICANTS

- Multi-purpose grease

## 1.2 Locking lever

### Locking lever

#### Requirements

- Coupling closed
- Hand lever removed; Section 1.1

#### TOOLS:

- 2x open-end, ring or fork spanner, 8 mm



#### Removal

- Release and remove the bolt [3A]
- Remove cap [3B]
- Press the closing lever [3C] all the way down and hold it there
- Remove the locking lever [3D]

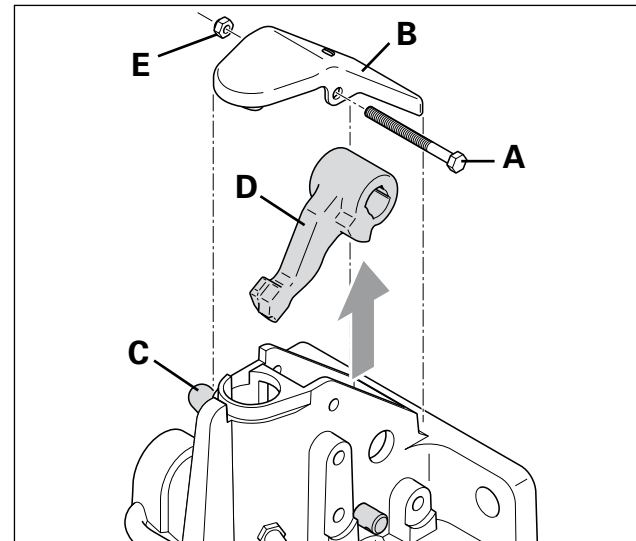

- [3] **A** Bolt  
**B** Cap  
**C** Closing lever  
**D** Locking lever  
**E** Locking nut

### Installation

The installation takes place in the reverse sequence. Please take note of the following points:

- Before installation, thoroughly clean and grease the inside of the housing
- When fitting the cap, make sure that the cap spring [4A] is correctly fitted
- Replace locking nut [3E] M5 DIN 98N
- Install hand lever; Section 1.1
- Check the coupling for correct functioning; Section 2.1

### LUBRICANTS

- Multi-purpose grease

### TIGHTENING TORQUES:

- Bolt and nut [3A/E]  
on cap ..... 6 + 2 Nm

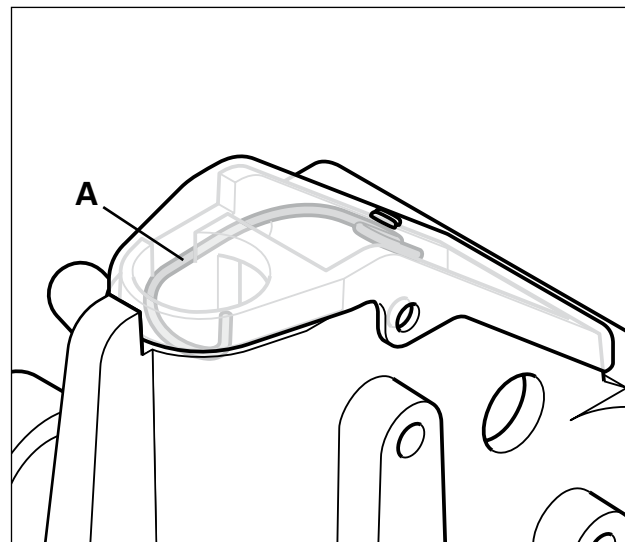

[4] A Cap spring





## 1.3 Closing lever

### Closing lever

#### Requirements

- Coupling closed
- Hand lever removed; Section 1.1
- Locking lever removed; Section 1.2

#### TOOLS:

- flat-tip screwdriver, medium

#### Removal

- Press the release lever [5B] slightly back and hold it there
- Pull out the closing lever [5A]

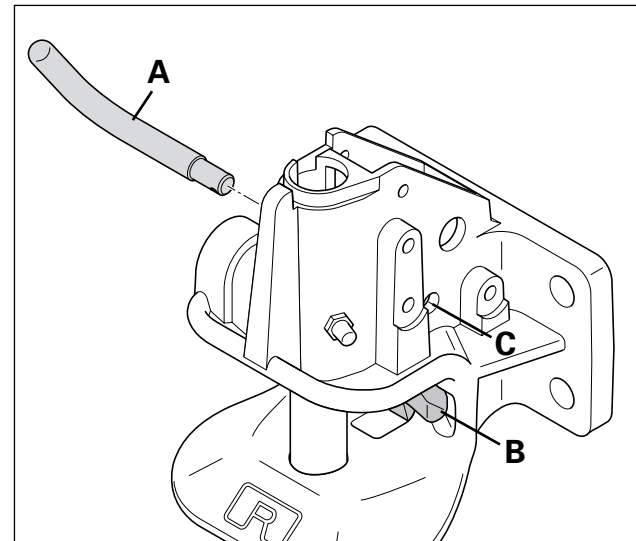

- [5] **A** Closing lever  
**B** Release lever  
**C** Housing boring

**Installation**

- Press the release lever [5B] slightly back (y-direction) and hold it there
- Slide in the closing lever [5A]
- Check the release lever [5B] for correct function and smooth running
- Install the locking lever; Section 1.2
- Install the hand lever; Section 1.1
- Check the coupling for correction functioning; Section 2.1

**NOTE!**

If the release lever slips, it can be centred through the housing boring [5C] using the flat-tip screwdriver.

## 1.4 Coupling pin

### Coupling pin

#### Requirements

- Coupling closed
- Hand lever removed; Section 1.1
- Locking lever removed; Section 1.2
- Closing lever removed; Section 1.3

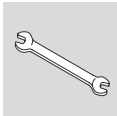

#### TOOLS:

- flat-tip screwdriver, medium
- Locking plate for control pin, part no. ROE65632

#### Removal

- Use the screwdriver to press the control pin [6A] outwards and arrest it using the locking plate [6B]
- Remove the coupling pin [6C] from the top

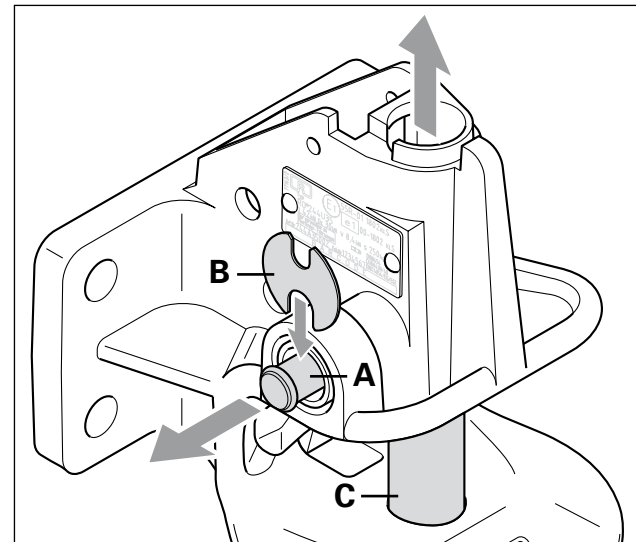

- [6] **A** Control pin  
**B** Locking plate, part no. ROE65632  
**C** Coupling pin

### **Installation**

The installation takes place in the reverse sequence. Please take note of the following points:

- Clean and grease the guide boring for the coupling pin thoroughly
- Install closing lever; Section 1.3
- Install locking lever; Section 1.2
- Install hand lever; Section 1.1
- Check the coupling for correct functioning; Section 2.1



### **LUBRICANTS**

- **Multi-purpose grease**

## 2.1 Function check

### Function check

#### Procedure

- Press the hand lever [7E] upwards until it engages
- The control pin [7B] must now be clearly projecting (12 mm)
- Press the closing lever [8A] down all the way.
- The control pin [8B] should now be no longer projecting



#### NOTE!

If the control pin is still projecting when the coupling is closed [9A]

- Replace the locking device,  
Repair instructions RO \* 244-2  
[www.jost-world.com](http://www.jost-world.com)
- Replace the locking lever; Section 1.2

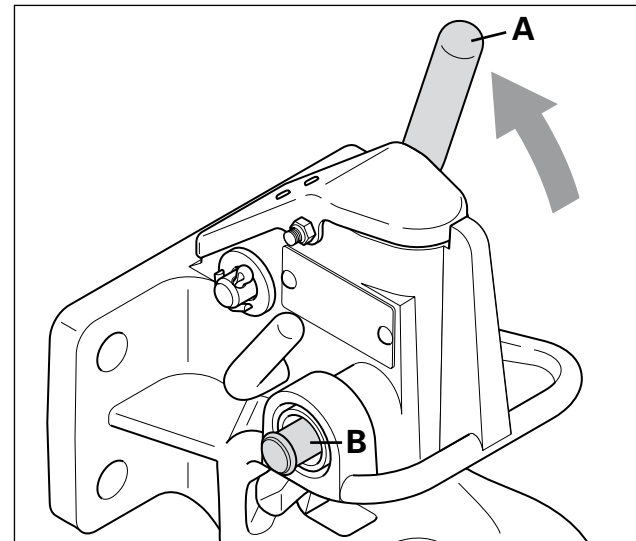

[7] **A** Hand lever  
**B** Control pin

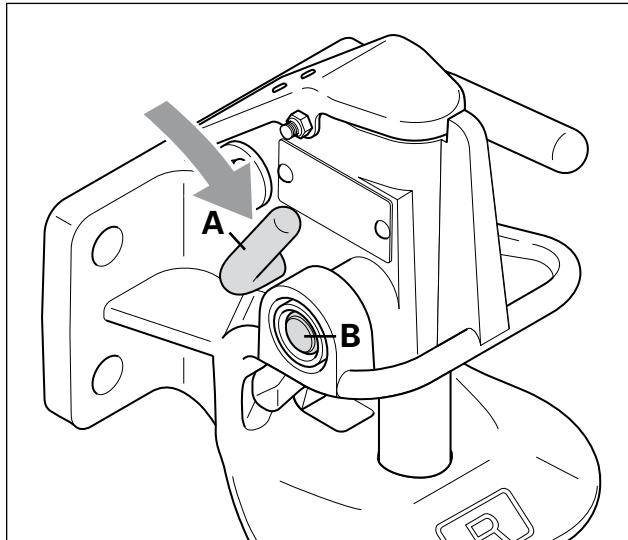

[8] **A** Closing lever  
**B** Control pin



[9] **A** Wrong

[9] **B** Correct

Control pin in closed position



Technische Änderungen vorbehalten.  
Aktuelle Informationen finden Sie unter:  
[www.jost-world.com](http://www.jost-world.com)

Technical modifications reserved.  
For up-to-date information, please visit:  
[www.jost-world.com](http://www.jost-world.com)

Sous réserve de modifications techniques.  
Vous trouverez des informations mises à  
jour sur le site :  
[www.jost-world.com](http://www.jost-world.com)

JOST-Werke  
Siemensstr. 2  
D-63263 Neu-Isenburg  
Telefon +49(0)61 02295- 0  
Fax +49(0)61 02295-298  
[www.jost-world.com](http://www.jost-world.com)